



Manual

EN

Appendix

Buck-Boost DC-DC converter 25A and 50A

Contents

1. General Description
 - 1.1 Applications
 - 1.2 General features
2. Connections
3. LED indicators
4. Engine running detection
5. Charge current limiter
6. Freely programmable (engine running detection and connected users)
7. Wiring diagram
8. ConverterMonitor PC application
9. Technical specifications



1. General Description

The Buck-Boost DC-DC convert will charge a 12V or 24V service battery in vehicles with a smart alternator. The converter charges the auxiliary battery with a pre-set charge voltage, eliminating high voltages (e.g. Mercedes: 15,4V) and low voltages.

1.1 Applications

- Controlled charging of the service battery
- Automatic activation and deactivation of electric devices in vehicles controlled by a unique engine running detection protocol (no annoying cables).

1.2 General features

- Buck-Boost converter can be fully programmed
- Suitable for all types of batteries
- Compact size
- Input voltage 10-30 VDC
- Output voltage 2-30 VDC (12/24 VDC variable settings)
- Adjustable current limiter
- Temperature monitoring
- Automatic activation when engine running
- LED status indicators
- Battery monitor by means of 2 RGB LEDs
- M8 connections
- Output for activation/deactivation of loads
- USB for configuration/monitoring
- Built-in Lithium battery low-voltage protection
- Two converters can be connected parallel when the settings are identical

2. Connections

The converter has three M8 bolt connectors for in- and output power, a two wire connector that can be used as inputs or outputs and an USB connector to connect to a computer to configure the device.

- IN Converter input (dynamo/starting battery)
- GND GROUND (chassis)
- OUT Converter output (additional battery)
- Pin 1 Input/output (purple wire)
- Pin 2 Input/output (green wire)

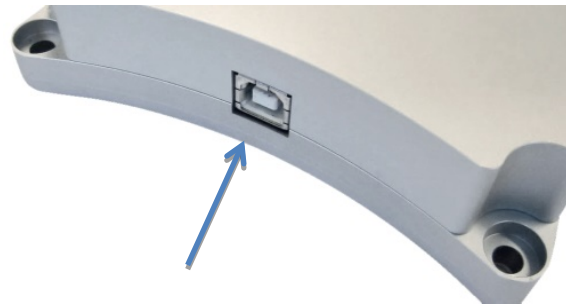
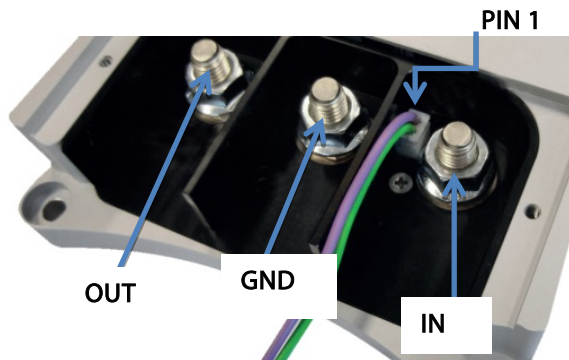

USB connection for configuring the converter

3. LED indicators

The Buck-Boost DC-DC converter has two RGB LEDs.

The IN LED has the following functions:

- Green: converter ON (by the engine running detection system or by voltage on pin 1).
- Yellow: converter OFF, the input voltage is lower than the set low voltage shut down threshold.
- Red: converter OFF, over temperature.
- Blue, quick flash: the engine running detection is active, the converter will turn ON after a delay.
- Blue, slow flash: the converter is OFF and activation is blocked due to low input voltage.

The OUT LED has the following functions:

- Green: converter OFF, battery voltage OK.
- Yellow: converter OFF, battery voltage low.
- Red: converter OFF, battery completely discharged or not connected.
- Purple: converter ON and is supplying power to the battery and/or the electrical users which are connected.

Output LED Indicator Input LED Indicator

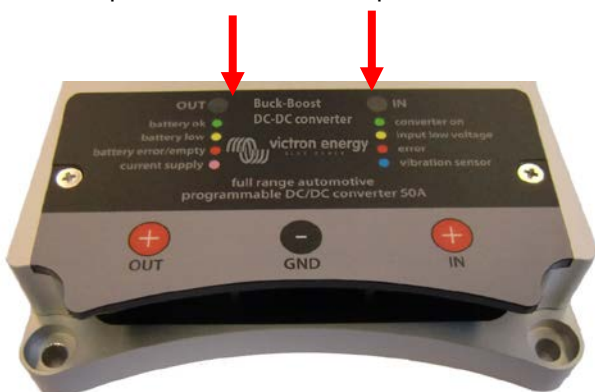

4. Engine running detection

The converter has a unique engine running detection system. This prevents the converter from discharging the starter battery if no power is being supplied by the alternator. The converter turns ON when the engine is running and the input voltage exceeds the pre-set voltage.

5. Charge current limiter

The output current is determined by the following factors:

Setting: the maximum required charge current is set via the USB connection (with the Windows ConverterMonitor application)

Temperature: if the internal converter temperature attains the maximum temperature setting, the charge current is automatically limited so that the internal temperature never becomes impermissibly high.

Input current: the maximum input current is set via the USB connection (with the Windows ConverterMonitor application). The maximum input current setting prevents the starter battery and/or the alternator from being overloaded. This also facilitates the choice of cable diameter and fuse.

6. Freely programmable (engine running detection and connected users)

P1 enables you to define the engine running detection system in a number of ways. P1 is the Purple wire.

P2 enables you to programme activation and deactivation of connected users. P2 is the green wire.

7. Wiring diagram

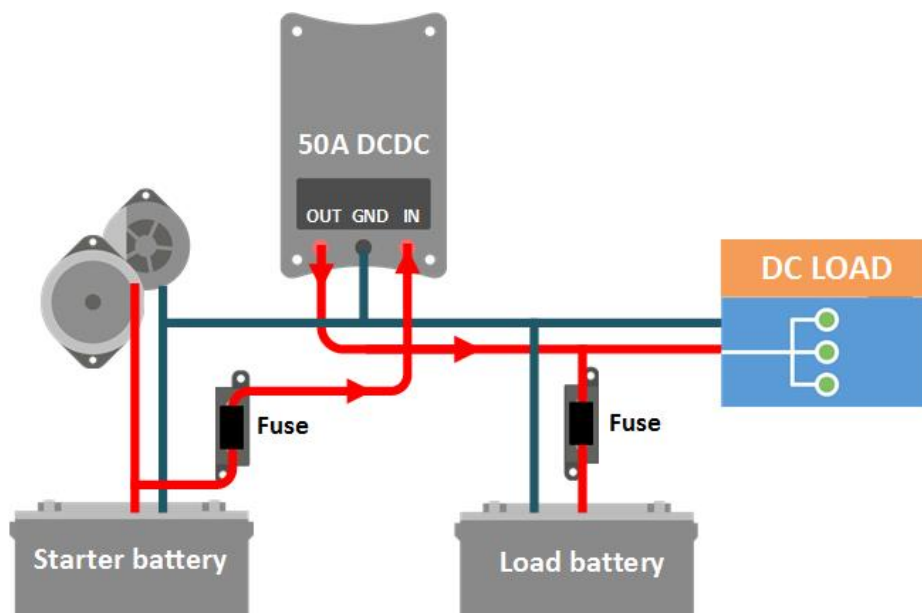

8. ConverterMonitor PC application

With the ConverterMonitor pc program it is possible to monitor the live values of the converter:

- Input voltage
- Output voltage and current
- Temperature

It is also possible to configure the converter by setting various parameters:

- Output voltage
- Maximum input and output current
- Maximum temperature
- Under voltage threshold
- Power save mode timer
- Battery levels
- Motor detection settings
- How the 2 input/output pins are used

This screenshot of the ConverterMonitor application shows the status and the parameters that can be configured.



9. Technical specifications

Buck-Boost DC-DC Converter	25A	50A
Input voltage range	7-35V	
Under voltage threshold	10V	
Output voltage range	2-30V	
Maximum charge current	12V : 25A 24V : 15A	12V : 50A 24V : 25A
Power consumption		
Converter off, LEDs off (power save mode)	7mA	
On/off input (pin 1, purple wire)		
'On' threshold voltage	> 2V	
Maximum input voltage	60V	
Output pin 1 and pin 2		
Output voltage if activated	$V_{pinout} = V_{in}$	
Maximum current (per pin)	$I_{pinout} = 1 \text{ A}$	
GENERAL		
Operating temperature range	-25 +80°C	
Ambient temperature	Max current: up to 40°C	
Weight	1kg	1,1kg
Dimensions	165 x 120 x 30 mm	213 x 120 x 30 mm

Victron Energy Blue Power

Distributor:

Version: 01

Date : 21 March, 2016

Victron Energy B.V.
De Paal 35 | 1351 JG Almere
PO Box 50016 | 1305 AA Almere | The Netherlands

General phone : +31 (0)36 535 97 00
Customer support desk : +31 (0)36 535 97 03
Fax : +31 (0)36 535 97 40

E-mail : sales@victronenergy.com

www.victronenergy.com